

ZXV10 B866V2F
Set Top Box
User Guide

LEGAL INFORMATION

Copyright © 2024 ZTE CORPORATION.

The contents of this document are protected by copyright laws and international treaties. Any reproduction or distribution of this document or any portion of this document, in any form by any means, without the prior written consent of ZTE CORPORATION is prohibited. Additionally, the contents of this document are protected by contractual confidentiality obligations.

All company, brand and product names are trade or service marks, or registered trade or service marks, of ZTE CORPORATION or of their respective owners.

This document is provided as is, and all express, implied, or statutory warranties, representations or conditions are disclaimed, including without limitation any implied warranty of merchantability, fitness for a particular purpose, title or non-infringement. ZTE CORPORATION and its licensors shall not be liable for damages resulting from the use of or reliance on the information contained herein.

ZTE CORPORATION or its licensors may have current or pending intellectual property rights or applications covering the subject matter of this document. Except as expressly provided in any written license between ZTE CORPORATION and its licensee, the user of this document shall not acquire any license to the subject matter herein.

ZTE CORPORATION reserves the right to upgrade or make technical change to this product without further notice. Users may visit the ZTE technical support website <http://support.zte.com.cn> to inquire for related information.

The ultimate right to interpret this product resides in ZTE CORPORATION.

History Revision

| Revision No. | Revision Date | Revision Reason |
|--------------|---------------|-----------------|
| R1.0 | 2024-05-22 | First edition |

Serial No.: SJ-20240522110050-001

Content

| | |
|--|----|
| Chapter 1 Safety Instructions..... | 1 |
| Chapter 2 Packing List..... | 3 |
| Chapter 3 Panels..... | 4 |
| 3.1 Front Panel..... | 4 |
| 3.2 Rear Panel..... | 4 |
| 3.3 Side Panel..... | 5 |
| Chapter 4 Connecting Up..... | 6 |
| 4.1 Connecting Network..... | 6 |
| 4.2 Video and Audio Connections..... | 6 |
| 4.3 Power ON..... | 8 |
| 4.4 Upgrade..... | 8 |
| Chapter 5 Remote Control..... | 9 |
| Chapter 6 Operation Guide..... | 10 |
| Chapter 7 Troubleshooting..... | 11 |
| Chapter 8 Technical Specification..... | 13 |

Chapter **1** **Safety Instructions**

Special Note

- Remove the plastic covering before using the Set-Top Box to provide normal ventilation.
- Use the power adapter provided with the Set-Top Box.

Important Safety Instructions

- Ensure that the electric voltage meets the device requirements. Check the cables periodically, replace any damaged cables immediately.
- To prevent electric shock, do not remove cover. There are no user serviceable parts inside. Refer servicing to qualified service.
- Do not use this apparatus near water.
- Clean with only dry cloth.
- Place the device on a flat surface. Do not place any heavy objects on the device.
- Do not block any ventilation openings. Install according to the manufacturer's instructions.
- Do not install near any heat sources, such as radiators, heat registers, stoves, or other apparatus (including amplifiers) that produce heat.
- Only use attachments/accessories specified by the manufacturer.
- Power off and pull out the power plug if the device will not be used for a long time or during lightning storms.
- After power off, wait at least 15 seconds between power off and next power-on.
- For the adapter, the socket-outlet shall be installed near the adapter and shall be easily accessible.
- All unpacked devices must be powered on within half a year.
- If a device is no longer in use or needs to be replaced, restore it to factory settings.

Service

Do not disassemble the device. Contact the service provider if the following problems occur:

- The power cable or power socket is damaged.
- There is any liquid leaks into the device.
- Fails to run normally even after following the instructions.
- The device is physically damaged.

RF exposure information:

The Maximum Permissible Exposure (MPE) level is calculated based on a distance of $d=20$ cm between the device and the human body. To maintain compliance with the RF exposure requirement, a separation distance of 20 cm between the device and the human should be maintained.

Restrictions in the 5 GHz band

According to Article 10(10) of Directive 2014/53/EU, the packaging shows that this radio equipment will be subject to some restrictions when placed on the market in Belgium(BE), Bulgaria(BG), the Czech Republic(CZ), Denmark(DK), Germany(DE), Estonia(EE), Ireland(IE), Greece(EL), Spain(ES), France(FR), Croatia(HR), Italy(IT),Cyprus(CY), Latvia(LV), Lithuania(LT), Luxembourg(LU), Hungary(HU), Malta(MT), Netherlands(NL), Austria(AT), Poland(PL), Portugal(PT), Romania(RO), Slovenia(SI), Slovakia(SK), Finland(FI), Sweden(SE), Turkey(TR), Norway(NO), Switzerland(CH), Iceland(IS), and Liechtenstein(LI). The WLAN function for this device is restricted to indoor use only when operating in the 5150 to 5350 MHz frequency range.

Caution!





Any changes or modifications not expressly approved by the party responsible for compliance could void the user's authority to operate the equipment.

EU Declaration of Conformity

Hereby, ZTE Corporation declares that the radio equipment types ZXV10 B866V2F are in compliance with Directive 2014/53/EU, The full text of the EU declaration of conformity is available at the following Internet address:

<https://support.zte.com.cn/support/cer/EU>

Chapter 2 Packing List

| Quantity | Item | Remarks |
|----------|-------------------|---|
| 1 | Set-Top Box (STB) |  |
| 1 | Remote control |  |
| 2 | AAA battery |  |
| 1 | HDMI cable |  |
| 1 | Power adapter | - |

Notes:

This packing list is for reference only. The items actually delivered depend on the companion packing list of the STB. Contact the provider immediately if parts are missing or damaged. Keep all packaging and available components for return purposes.

Chapter 3 Panels

3.1 Front Panel

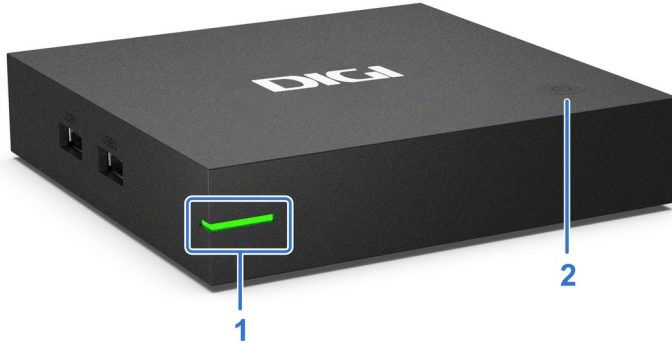

| Key | Name | Description |
|-----|-----------------|---|
| 1 | Power indicator | Red: STB is in standby state. Green: STB is running normally. Not Lit: STB is not powered on. |
| 2 | Power switch | Press it to switch between running and standby state. |

3.2 Rear Panel

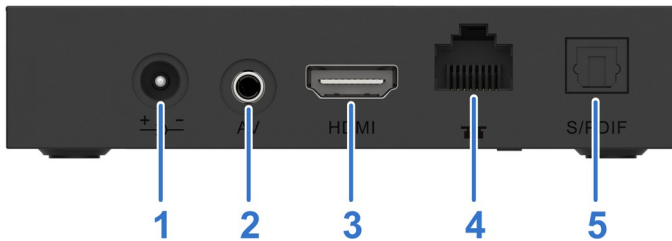

| Key | Name | Description |
|-----|----------|---|
| 1 | DC +12 V | Power input socket, +12 V DC power adapter provided. Consult technical engineer before using other types of power adapter. |
| 2 | AV | Audio and composite video output interface. |
| 3 | HDMI | HDMI output interface. |
| 4 | WAN | 10 M/100 M Base-T RJ45 self-adaptive Ethernet interface. |
| 5 | S/PDIF | S/PDIF interface. |

3.3 Side Panel

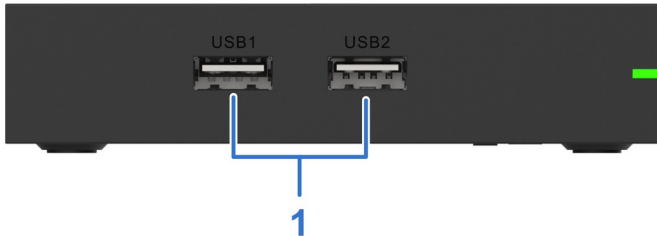

| Key | Name | Description |
|-----|------|----------------|
| 1 | USB | USB interface. |

Chapter 4 Connecting Up

4.1 Connecting Network

This section introduces the network connection methods for STB. Select one method to connect according to the on-site conditions.

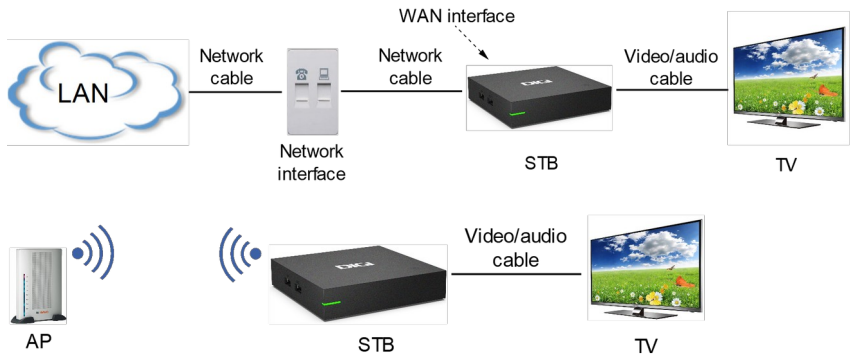

4.2 Video and Audio Connections

Steps

- Connecting 3.5 mm RCA AV Output Interface
1. Connect the **R** and **L** interfaces on the TV to the corresponding interfaces with the AV cables.
 2. Connect the **AV** interface on the TV with the AV cable (yellow), as shown in the follow figure.

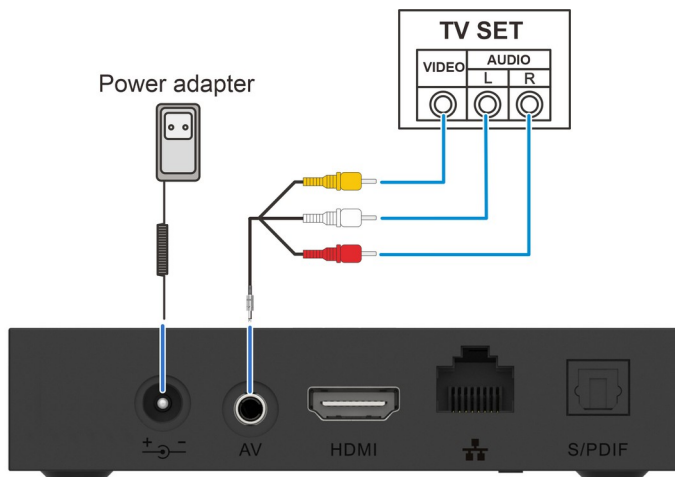

- Connecting High Definition Interface

Connect the HDMI interface on the STB and TV with HDMI cable, as shown in the follow figure.

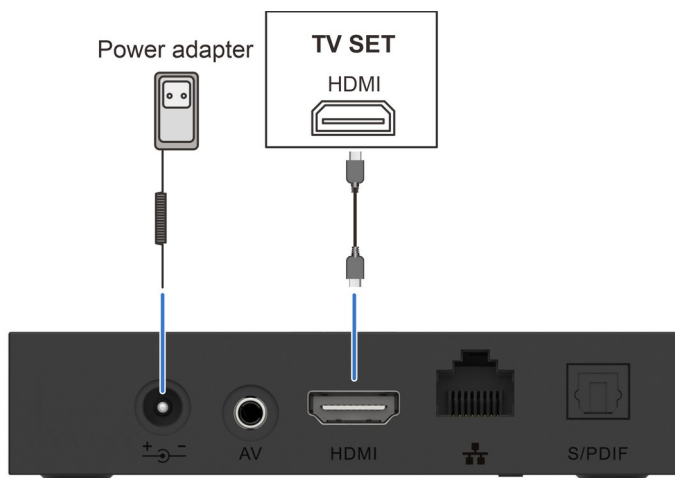

—END OF STEPS—

4.3 Power ON

Steps

1. Ensure that all cables are connected correctly.
2. Install the power cable to STB using the power adapter and to AC power source.
3. Ensure that all other devices are plugged in and receiving power.
4. Turn on the TV.

—END OF STEPS—

4.4 Upgrade

The STB can connect to the server on each power-on and check whether an upgrade is required. If so, the upgrade starts at once, which normally takes about ten minutes. Do not perform any operations during this period.



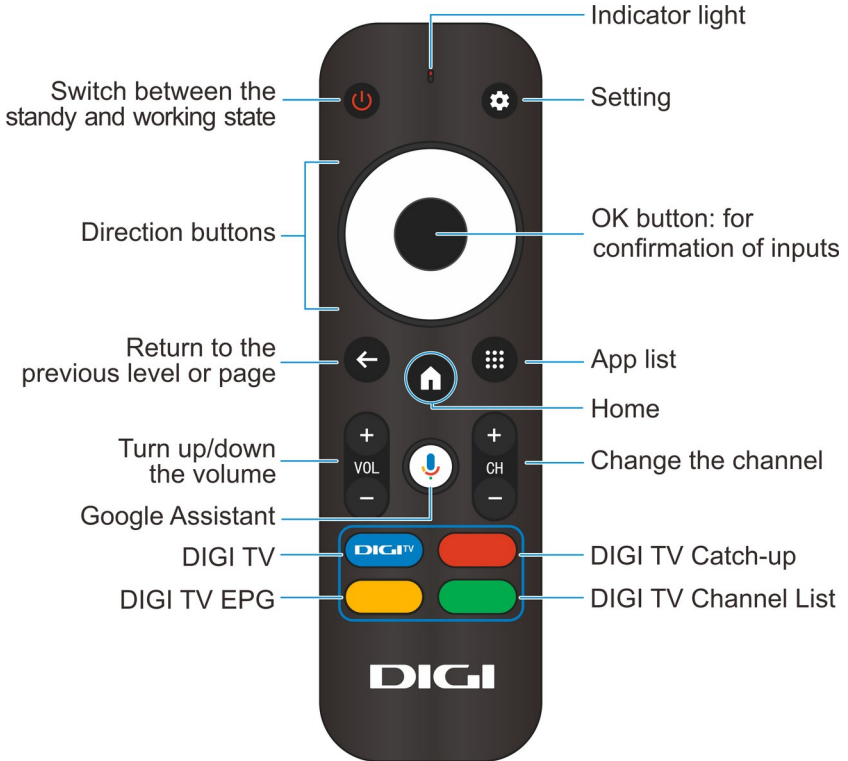





Chapter 5 Remote Control





Notes:



- The remote control is powered by two AAA batteries. Insert two AAA batteries into the remote control according to the polarity instruction displayed on it.
- The remote control works on the infrared mode by default. When the Bluetooth pairing is successful, the infrared function will be closed.
- When the infrared function works, point the front part of the remote control to the infrared receiving area on the STB during the operation.

Chapter 6 Operation Guide

| Common Operations | |
|---|---|
|  | Switch between the standby and working state. |
|  | Press the key on the remote control to enter the Launcher homepage. |
|  | Press direction keys (up, down, left, and right) on the remote control to select an item. Press OK key to confirm the selection. |
|  | Long press  key to begin voice pickup, indicator light on; loose the key to stop the voice pickup and indicator light off. |
| Volume Operations | |
|  | Turn up/ down volume of STB. |
| Pairing operation | |
| a. Long press at the  (OK) +  button for 3 seconds (indicator light flashes), until pairing successful. Indicator light will turn to be always on for 3 seconds and then turns off. | |



Chapter 7 Troubleshooting

| Problem | Possible Cause | Solution |
|---|--|--|
| The indicator is not lighting after switching on the STB. | The power adapter has not been connected. | Connect the power adapter. |
| | The power adapter is damaged. | Consult the service provider and replace power adapter with a new one. |
| | The power outlet has no power. | Check and ensure the power outlet has power. |
| Network connection failed. | The network has not been connected properly. | Connect the network cable properly or replace it with a new cable. Check the Wi-Fi connection configuration. |
| No signal on the TV screen. | The STB is in standby. | Turn on STB by pressing the  key on the remote control. |
| | The video cable has not been connected properly. | Reconnect video cable. |
| | The video input source of the TV has not been set correctly. | Switch to the correct video source of the TV. |
| No sound from the TV. | The STB is in standby. | Turn on STB by pressing  key on the remote control. |

| Problem | Possible Cause | Solution |
|---------------------------|--|---|
| | The STB is set as Mute | Press Vol+ or Vol- on the remote control |
| The remote control fails. | The remote control is physically damaged. | Change a new remote control. |
| | The Bluetooth pairing fails. | Long press at the  (OK) +  for 3 seconds (indicator light flashes), until pairing successful. Indicator light will turn to be always on for 3 seconds and then turns off. |
| | There is no battery in the remote control, or the batteries are installed incorrectly. | Install the batteries correctly. |
| | The batteries are damaged. | Replace the batteries. |
| | TV cannot receive instructions from remote control. | Keep the remote control closer to STB. Ensure Bluetooth are paired between the STB and the remote control. |
| Other problems | - | Restart STB or call the customer service hotline. |

Chapter 8 Technical Specification

| | |
|---|---|
| Power Adapter | Input: 100 V ~ 240 V, 50 Hz ~ 60 Hz Output: +12.0 V DC |
| Environment Requirement | Working environment temperature: +32 °F (0 °C) ~ +104 °F (+40 °C) |
| | Working environment humidity: 10% ~ 90% |
| Protocol | TCP/IP, HTML 4.0, HTTP 1.1/JavaScript 1.5, NTP, FTP, HTTPS/SSL2.0/3.0, RTSP, RTP, RTCP, and HLS |
| Wi-Fi Radio Specifications | Radio Frequencies/Maximum Output Power: Wi-Fi 2.4 GHz band: 2412 ~ 2472 MHz / EIRP: 20 ± 1 dBm Wi-Fi 5G Hz band: 5180 ~ 5825 MHz / EIRP: 20 ± 1 dBm |
| BT Radio Specifications | Radio Frequencies/Maximum Output Power: BT band: 2402~2480 MHz/EIRP: 15 ± 1 dBm |
| Video | Supports PAL, NTSC, 720p, 1080i, 1080p, and 4K |
| | Format: 4:3/16:9 |
| | Receiving bit rate range: 200 kbps ~ 40 Mbps |
| | Resolution: 720 × 576/PAL, 720 × 480/NTSC, 1280 × 720 /720p, 1920 × 1080 /1080i, 1920 × 1080 /1080p, and 3840×2160/4K |
| Audio | Dolby Digital and Dolby Digital Plus |
| | Surround, Single/Dual/Multi Track and Stereo |
| Dimension | 108 mm × 108mm × 23 mm (Length × Width × Height) |
| Weight | 0.14 kg |
|  | HDMI, the HDMI Logo, and High-Definition Multimedia Interface are trademarks or registered trademarks of HDMI Licensing LLC in the United |

| | |
|--|--|
| | States and other countries. |
|  Dolby Audio | Manufactured under license from Dolby Laboratories. Dolby, Dolby Audio and the double-D symbol are trademarks of Dolby Laboratories. |
| Certification |  |
| REACH | - |

 **Notes:**

Google, Google Play and YouTube are trademarks of Google LLC.

All specifications are subject to the actual product.